

PARTS FOR 175 LB. POLY "PRO" SPIKER/SPREADER MODEL 45-0545

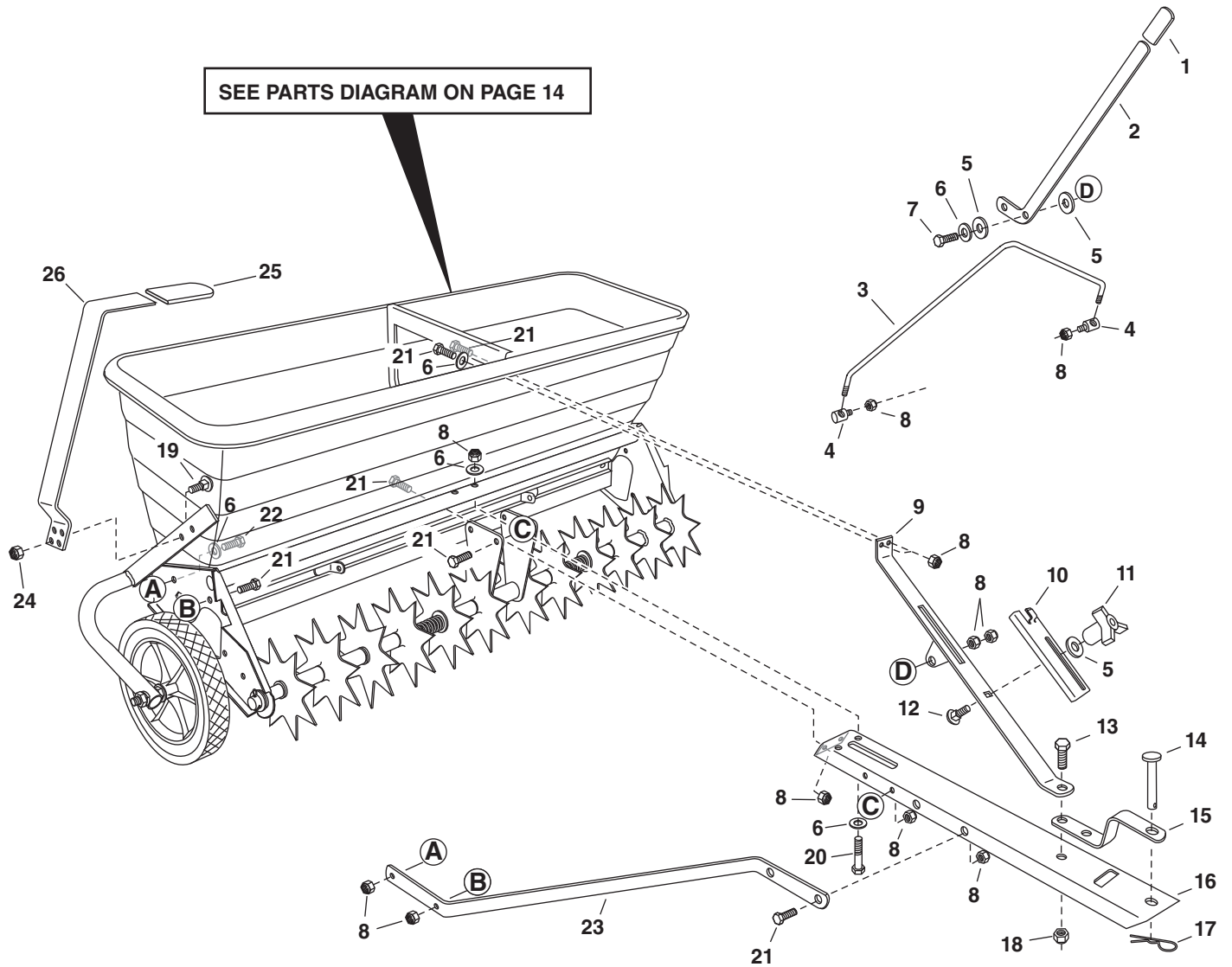

REF NO.	PART NO.	QTY	DESCRIPTION	REF NO.	PART NO.	QTY	DESCRIPTION
1	43848	1	Plastic Grip	14	47623	1	Pin, Hitch 3/8" Flat Hd.
2	24660	1	Flow Control Arm	15	23014	1	Hitch Bracket
3	47712	1	Flow Control Rod	16	24531	1	Tongue
4	47711	2	Ferrule	17	43343	1	Pin, Hair Cotter #4 (1/8")
5	1543-69	3	Nylon Washer	18	HA21362	1	Nut, Nylock 3/8-16 Thd.
6	43088	8	Washer, 1/4"	19	44326	2	Bolt, Carriage 5/16-18 x 1"
7	1509-90	1	Bolt, Hex 1/4-20 x 1-1/4" Lg.	20	1509-69	2	Bolt, Hex 1/4-20 x 1-3/4"
8	47189	22	Nut, Nylock 1/4-20 Thd.	21	43866	14	Bolt, Hex 1/4-20 x 5/8"
9	63850	1	Brace Assembly, Hopper	22	43012	2	Bolt, Hex 1/4-20 x 3/4"
10	24542	1	Flow Control Gauge	23	24532	2	Tongue Brace
11	43849	1	Plastic Knob, 1/4-20 Thd.	24	47810	2	Nut, Nylock 5/16-18
12	44950	1	Bolt, Carriage 1/4-20 x 3/4" Lg.	25	47707	1	Handle Grip
13	43001	1	Bolt, Hex 3/8-16 x 1" Lg.	26	24647	1	Transport Handle Bar

PARTS FOR 175 LB. TOW SPIKER SPREADER MODEL 45-0545

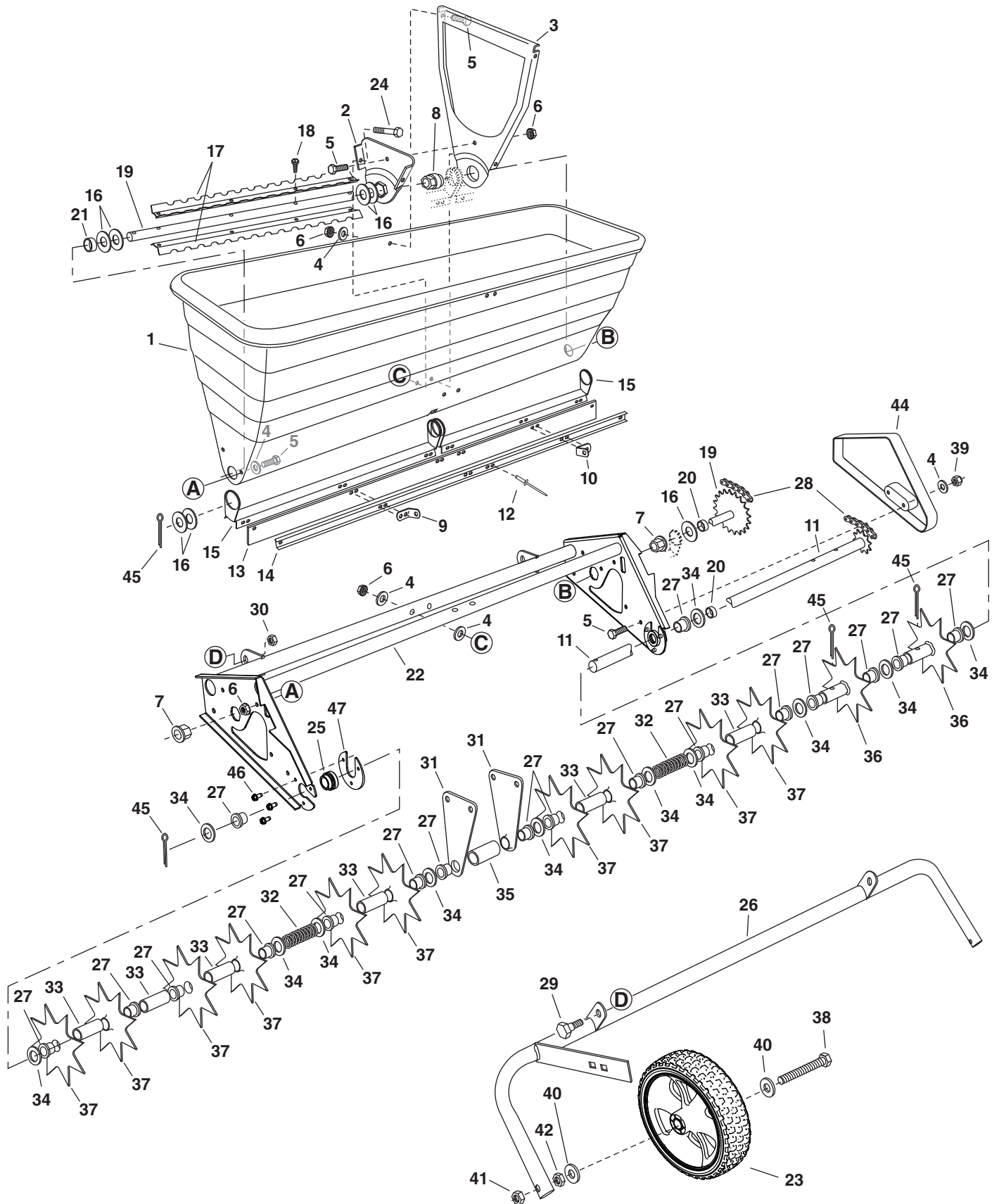

PARTS FOR 175 LB. TOW SPIKER SPREADER MODEL 45-0545

REF NO.	PART NO.	QTY	DESCRIPTION	REF NO.	PART NO.	QTY	DESCRIPTION
1	47451	1	Hopper	25	26007	2	Step Bushing (Special)
2	24536	1	Hopper Center Plate (Small)	26	69441	1	Lift Tube Assembly
3	24535	1	Hopper Center Plate (Large)	27	741-0249	18	Bearing, Flanged 0.63" I.D.
4	43088	9	Washer, 1/4"	28	47684	1	Chain with Connector
5	43866	4	Bolt, Hex 1/4-20 x 5/8"	29	48106	2	Bolt, Shoulder 3/8-16 x 5/8"
6	46978	6	Nut, Hex (SIMS) 1/4-20 Thd.	30	43082	2	Nut, Hex Lock 3/8-16
7	47615	2	Bearing, Flange	31	24648	2	Center Brace
8	47484	1	Bearing, Hex Flange	32	47777	2	Compression Spring
9	24538	1	Bracket, Feed Plate (RH)	33	47683	6	Spacer, .75" x 1.0" x 2.98"
10	24539	1	Bracket, Feed Plate (LH)	34	R19212016	12	Washer, 21/32 x 1-1/4 x 16 ga.
11	63949	1	Axle w/Sprocket, 5/8"	35	47782	1	Spacer, 1.0" ID x 3.25"
12	728-3001	10	Pop Rivet	36	69416	2	Drive Disk Assembly
13	47459	1	Skirt, 48"	37	28606	10	Spike Disk (7")
14	47508	1	Skirt Retainer	38	45100	2	Bolt, Hex 1/2-13 x 4"
15	24537	2	Flow Plate	39	47189	2	Nut, Nylock 1/4-20
16	43009	10	Washer	40	R19171616	4	Washer, 17/32" x 1" x 16 ga.
17	47259	4	Agitator Blade	41	48115	2	Nylock Hex Jam Nut, 1/2"
18	47978	16	Screw, #8-32 x 1/4" Lg.	42	43019	2	Nut, Hex Jam 1/2-13
19	63948	1	Axle w/Sprocket, 3/4"	43	HA24629	2	Tie, Plastic 30" (not shown)
20	46838	2	Spacer, .76" x 1.0" x 0.50"	44	47679	1	Chain Cover
21	47458	2	Spacer, 1.25" OD x .330" Lg.	45	43093	4	Cotter Pin, 1/8" x 1-1/2"
22	65790	1	Hopper Frame Assembly	46	48840	6	Screw, 1/4-20 x 1/2"
23	41863	2	Wheel	47	26005	2	Axle Retainer Bracket
24	1509-69	2	Bolt, Hex 1/4-20 x 1-3/4"		45601	1	Owners Manual

SpeedEPart *the fastest way to purchase parts* www.speedepart.com